



data communications
The Access Company

Do you have the right **timing**?



Clock recovery and distribution solutions for all-IP RANs

The evolution to all-IP cellular networks is picking up pace, accompanied by industry efforts to address synchronization over packet issues. For packet transport to be a viable backhaul technology for 2G/3G voice services, carrier-grade RAN (radio access network) backhaul solutions are required to deliver a combination of QoS/CoS transport guarantees, full functioning pseudowire capabilities and standardized timing distribution protocols (e.g., IEEE 1588-2008, ITU-T Synchronous Ethernet) that meet mobile services' synchronization requirements.

RAD's best-of-breed RAN gateways offer LTE-ready, robust synchronization solutions over packet switched networks and support full interoperability with Symmetricom's Grand Master Clocks.

Clock Recovery and Distribution Solutions for All-IP RANs

With state-of-the-art clock recovery and distribution schemes and multi-standard TDM and ATM pseudowire support, our cell-site, transport and aggregation site gateways incorporate critical attributes to support operators in their migration to all-IP cellular backhaul:

- **Reconstruct** original clocking data over packet, using standard pseudowire flows, to comply with G.823/824 synchronization interface requirements per G.8261 specifications
- **Interoperable** with third-party radio network elements such as the Cisco 7600, Nortel MSS and Alcatel 7750
- Support **definite frequency accuracy** limits for various services, including 50 ppb for GSM and 16 ppb for 2G CDMA and 3G UMTS
- Designed with the latest PTP (**precision time protocol**), IEEE 1588-2008 (1588v2) and **Sync-E** standards
- Feature **holdover mechanism** of 1 ppb per 24 hours to protect against clock stream failure
- Offer dedicated **unicast or multicast** pseudowires for clock distribution
- Ensure **QoS priorities** for clock traffic

Ensuring Accurate Synchronization for Multi-Generation Traffic with Multiple Clocking Standards

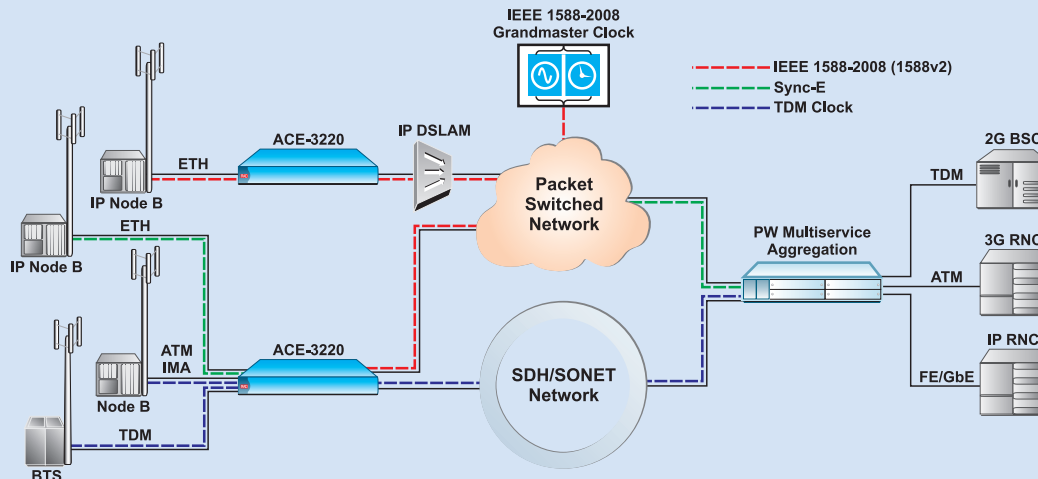

SLA Assurance for IP NodeB Traffic over Packet

